

**[Time: 3 Hours]**

**[ Marks:80]**

Please check whether you have got the right question paper.

- N.B:**
1. Q.1 is compulsory attempt any 3 questions out of remaining six questions.
  2. Assume any necessary data to justify the same
  3. Figures to the right indicate full marks
  4. Use of scientific calculator is allowed.

- Q.1 A** Determine whether the given relation is reflexive, irreflexive, and symmetric asymmetric antisymmetric and transitive. Also determines whether the relation is equivalence or not.  $R = \{(4,5),(5,4),(6,7)\}$  on  $A = \{4,5,6,7\}$  **10**
- B** Obtain principal disjunctive form  $(\sim P \vee \sim Q) \rightarrow (P \leftrightarrow Q)$  **5**
- C** Write the difference between MCDM and MADM. **5**

- Q.2 A** Using mathematical induction prove that **10**  
 $1^2 + 2^2 + \dots + n^2 = [n(n+1)(2n+1)]/6$

- Q.2 B** Find adjacency lists and adjacency matrix for the following graph **5**

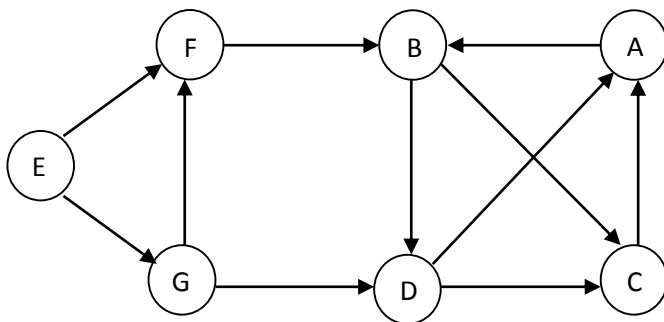

- Q.2 C** A manager has to make a choice from 3 available courses of action A1, A2, A3. There are 2 possible states of nature s1 and s2 with probabilities of occurrence as 0.7&0.3. for S1 the payoff for 3 actions is Rs.25000, Rs.35000 and Rs.20000 while for state S2 the payoffs are Rs.45000, Rs.50000 and Rs.35000. represent the problem with the help of a decision tree and suggest the most preferred decision and corresponding expected value. **5**

- Q.3 A** Draw a hasse diagram of poset(A,R) where  $A = \{1,2,3,6,8,12\}$  and the relation R define as a Rb iff 'a divides b. **10**
- B** Use SAW method and suggests the best alternatives? Where C1 and C3 are beneficiary criteria and C2 and C4 non beneficiary criteria? **10**

Weight	0.2	0.3	0.4	0.1
	C1	C2	C3	C4
A1	20	30	20	12
A2	10	30	25	30
A3	30	5	15	10
A4	20	10	20	10

**Q.P. Code :09902**

**Q.4 A** Prove the following argument without using truth table. If I try hard and I have talent then I will become a musician. If I becomes of musician then I will be happy .therefore I will not happy then either I didn't try hard or I do not have talent. **10**

**B** Perform fast multiplication of integer using divide and conquer approach **5**  
 1) 1214x550  
 2) 1025x7328

**C** What are the characteristics of a complex business problem, explain any two **5**

**Q.5 A** Determine whether sequence  $\{a_n\}$  is solution of recurrence relation  $a_n=2a_{n-1}-a_{n-2}$  for  $n = 2,3,4,\dots$  where  $a_n = 2^n$  for every non negative n **10**

**B** Let  $A=\{a,b\}$  and the relation is given by  $R=\{(a,a),(b,b), (a,b)\}$ ,determine whether it is a POSET or not? **5**

**C** An American roulette wheel has 38 equally likely outcomes. The numbers are 0, 00,1,2,3 .....36. A winning bet placed on a single number pays 35 to 1 i.e. you will be paid 35 times your bet is returned so you get 36 times your bet after your bet is collected. So considering all 38 possible outcomes and the expected value resulting from a \$1 bet on a single number. Calculate expected value. **5**

**Q.6 A** Find particular solution of  $a_r+5a_{r-1}+6a_{r-2}=3r^2$  **10**

**B** Find Euler circuit of following graph. **5**

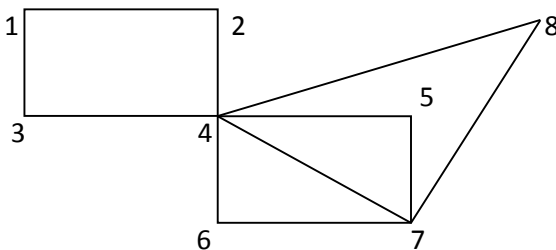

**C** Use WPM method and suggests the best alternatives. All as criteria are beneficiary criteria. **5**

Weight	0.20	0.15	0.40	0.25
	C1	C2	C3	C4
A1	25	20	15	30
A2	10	30	20	30
A3	30	10	30	10