

TIME- 3 hours**Total Marks: 80**

- N.B. 1) Question No. 1 is compulsory.
2) Attempt **any Three questions** from the remaining five questions.
3) Assume any suitable data if necessary with justification.
4) Figures to the right indicate full marks.
5) Use of design data book is permitted.
6) Draw neat sketches to support your answer wherever necessary.

Q. 1 Write Short Notes on (Any Four)**20**

- Factor of safety and factors considered for its selection
- Bolts of uniform strength
- Classification of Welded Joints with neat sketches
- Stress distribution in composite cylinders subjected to internal pressure
- Types of Keys
- Classification of riveted joints with neat sketches

Q. 2 a) Design a socket and spigot type of cotter joint to resist safely a tensile load of 30 KN. Take suitable material and stresses for different parts of the joint. **12**

- b)** Design a helical spring for a spring loaded safety valve for the following conditions: Diameter of valve seat = 70 mm, Operating pressure = 0.7 N/mm², Maximum Pressure when valve blows off freely = 0.75 N/mm², Maximum lift of the valve when the pressure rises from 0.7 to 0.75 N/mm² = 3.5 mm, Maximum allowable stress = 550 MPa, Modulus of rigidity = 84000 N/mm², Spring index = 6. **8**

Q. 3 a) A transmission shaft supporting a spur gear B and pulley D is mounted on bearings A and C. The diameter of the pulley and PCD of the gear are 450 mm and 300 mm respectively. The pulley transmits 20 KW power at 500 rpm to the gear. P_1 and P_2 are belt tensions in tight and slack side while P_t and P_r are tangential and radial components of the gear tooth force. Assume $P_1 = 3P_2$ and $P_r = P_t \tan 20^\circ$. The shaft material is steel 50C4 with $S_{ut} = 700 \text{ N/mm}^2$ and $S_{yt} = 460 \text{ N/mm}^2$. The factors K_b and K_t of the ASME code are 1.5 each. Determine the shaft diameter using ASME code. **14**

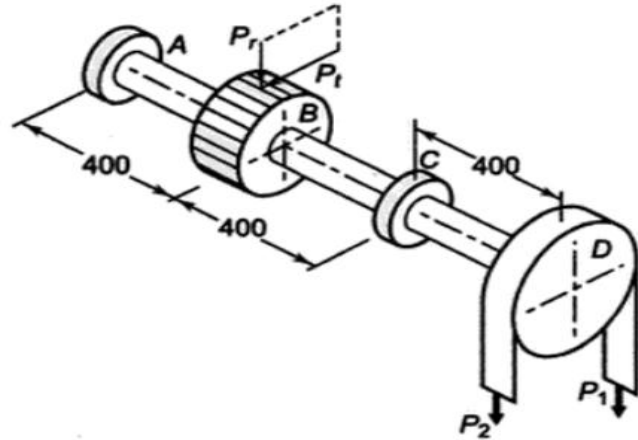

- b) A cast iron cylinder of internal diameter 340 mm and thickness 40 mm is subjected to a pressure of 6 N/mm^2 . Calculate the tangential and radial stresses at the inner, middle and outer surfaces of the cylinder. 6

- Q. 4 a) Design a cast iron flange coupling to transmit 20 KW at 900 rpm from an electric motor to compressor. The service factor may be assumed as 1.35. The following permissible stresses may be taken: Shear stress for shaft, bolt and key material = 40 MPa, crushing stress for bolt and key = 110 MPa, shear stress for cast iron = 10 MPa 10

- b) Design a double riveted butt joint with two cover plates for the longitudinal seam of a boiler shell 1.6 m in diameter subjected to a steam pressure of 0.92 MPa. Assume joint efficiency as 80%. Allowable tensile stress in the plate is 80 MPa, compressive stress 130 MPa and shear stress in the rivets is 60 MPa. 10

- Q. 5a) A rectangular cross section bar is welded to a support by means of fillet welds as shown in the figure. Determine size of the welds, if permissible shear stress in the weld is limited to 75 MPa. 10

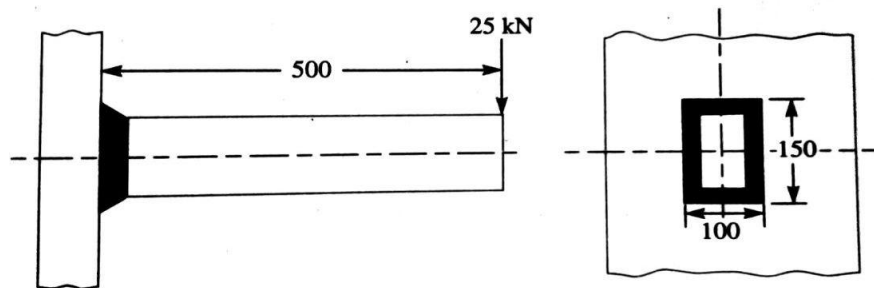

- b)** A pair of straight teeth spur gear having 20° full depth involute teeth is to transmit 12 KW power at 300 rpm of the pinion. The speed ratio is 3:1. Allowable static stresses for gear of cast iron and pinion of steel are 60 MPa and 105 MPa respectively. Design the module, face width for both pinion and gear. Use following data

Number of teeth on pinion = 17

Face width = 10 times module

Tooth form factor (y) = $0.514 - (0.912 / n)$, n = No. of teeth

Velocity factor (C_v) = $4.5 / (4.5 + V)$, V = pitch line velocity in m/sec.

10

- Q. 6 a)** A crane hook has trapezoidal section as shown in the figure. Find the total stresses at inner and outer fibers of the cross section X-X. The load lifting capacity of the hook is 80 KN.

8

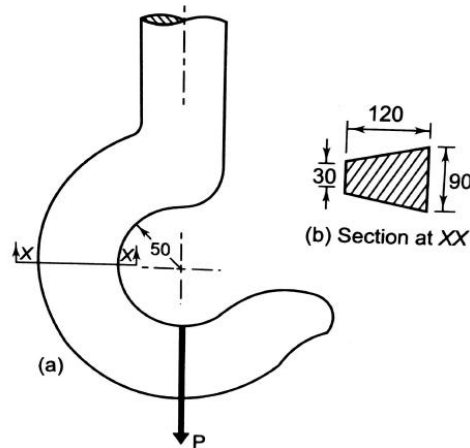

- b)** Explain different modes of failure in riveted joints with the help of neat sketches and governing equations.

6

- c)** What is spring index of a helical spring? Give its significance in design of helical spring.

6
