

3 hours

Total Marks: 80

NB

- **Q1 is compulsory.** Answer **any three** from the remaining **five** questions.
- Assume suitable data, wherever required. Clearly state the assumptions and justify the same.
- Illustrate answers with sketches, wherever required.
- Write legibly with blue or black ink pen. Use pencil only to draw diagrams and graphs.

1 Answer any four of the following:

- a. If a round bar of 37.5 mm diameter and 2.4 m length is stretched by 2.5 mm, find its bulk modulus and lateral contraction. Take, Young's modulus = 110 GN/m² and shear modulus = 42 GN/m² for the material of the bar. **05**
- b. A flitched beam consists of steel and timber as shown in figure. Determine the moment of resistance of the beam. Take $\sigma_s = 100 \text{ N/mm}^2$ and $\sigma_w = 5 \text{ N/mm}^2$. All Dimensions are in mm. **05**

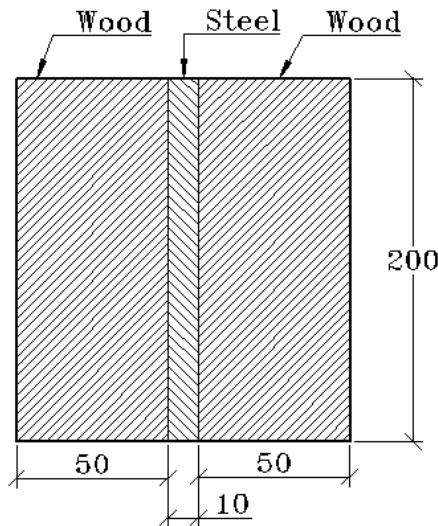

- c. Draw the S. F. and B. M. diagrams for the beam loaded shown in the figure. **05**

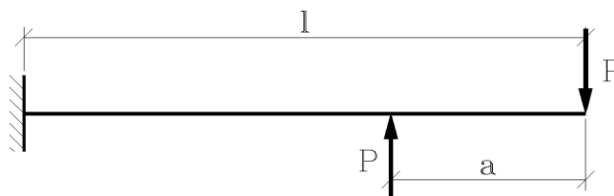

- d. Calculate the bursting pressure for a cold drawn seamless steel tubing of 60 mm inside diameter and 2 mm wall thickness. Ultimate Strength of steel is 380 N/mm². **05**
- e. Find the maximum power that can be transmitted through a 50 mm diameter shaft at 150 rpm, if the maximum permissible shear stress in the shaft is 80 N/mm². **05**

2a. A beam weighing 450 N is held horizontal by three vertical wires, one attached to the middle of the beam and the others to the ends of the beam. The outer wires are of brass with 1.25 mm diameter, and the central wire is of steel with 0.625 mm diameter. Estimate the stresses induced in the wires, assuming that the beam is rigid and the wires are of same length and un-stretched before attaching to the beam. Take Young's moduli of brass as $8.6 \times 10^4 \text{ N/mm}^2$ and of steel as $2.1 \times 10^5 \text{ N/mm}^2$. **10**

b. At a point in a material under stress, the intensity of the resultant stress on a certain plane is 50 N/mm^2 (tensile) inclined at 30° to the normal of that plane. The stress on a plane at right angles to this has a tensile component of intensity 30 N/mm^2 . Find,

- i. The resultant stress on the second plane
- ii. The principal planes and stresses
- iii. Plane of maximum shear and intensity

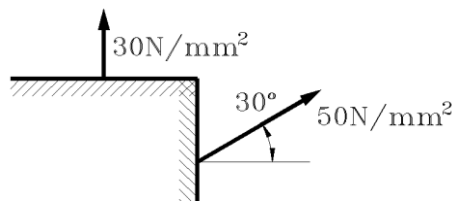

3a. For the beam shown below, draw A. F., S. F. and B. M. diagrams and mark important points. **10**

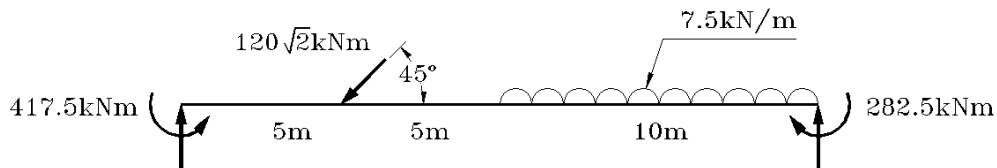

b. Determine the slope and deflection at the free end of the beam loaded as shown in the figure. $E = 200 \text{ GPa}$, $I = 14 \times 10^{-6} \text{ m}^4$ **10**

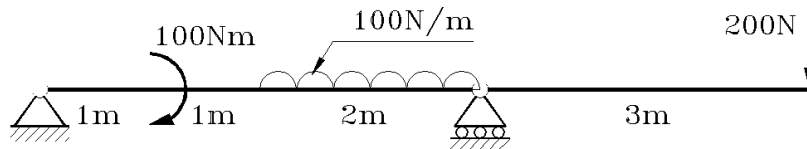

4a. A rectangular pier is subjected to a compressive load of 450 kN as shown in the figure. Find the stress intensities at the four corners of the pier. **10**

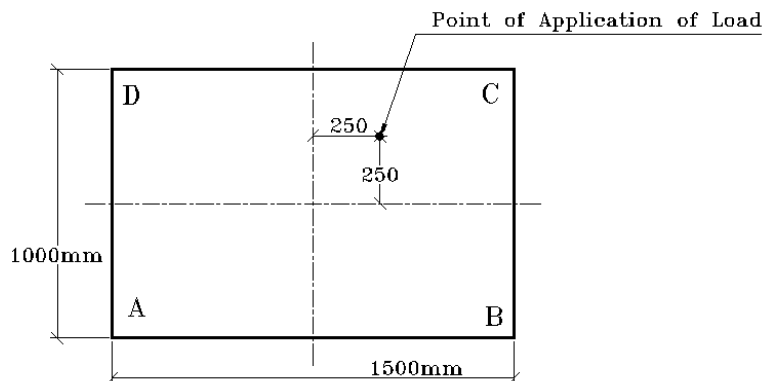

Internal diameter of a hollow shaft is 0.6 of its external diameter. It has to transmit **10** 300 kW power at 80 rpm. If the shear stress is not to exceed 60 N/mm^2 , find the internal and external diameters of the shaft, assuming that the maximum torque is 1.4 times the mean torque.

- 5a.** A 200 kg weight is dropped on to a collar at the lower end of a vertical bar of 3 m long **10** and 28 mm diameter. Calculate the height of drop, if the maximum instantaneous stress is not to exceed 120 N/mm^2 . What is the corresponding instantaneous elongation? Take $E = 2 \times 10^5 \text{ N/mm}^2$.
- b.** A simply supported beam, with a span of 1.3 m and a rectangular cross section of 150 **10** mm wide and 250 mm deep, carries a concentrated load of W at the centre. If the allowable stresses are 7 N/mm^2 for bending and 1 N/mm^2 for shear, what is the value of the safe load W ?
- 6a.** A hollow cast iron column of 200 mm external diameter, 150 mm internal diameter and **10** 8 m long has both ends fixed. It is subjected to axial compressive load. Taking factor of safety as 6, $\sigma_c = 560 \text{ N/mm}^2$, $\alpha = \frac{1}{1600}$, determine the safe Rankine load.
- b.** A weight of 200 kN is supported by three adjacent short pillars in a row, each 500 mm^2 **10** in section. The central pillar is made of steel and the outer ones are of copper. The pillars are adjusted such that at 15°C , each carries equal load. The temperature is then raised to 115°C . Estimate the stresses in each pillar at 15°C and 115°C . Take: $E_s = 2 \times 10^5 \text{ N/mm}^2$, $E_c = 0.8 \times 10^5 \text{ N/mm}^2$, $\alpha_s = 1.2 \times 10^{-5}/^\circ\text{C}$, $\alpha_c = 1.85 \times 10^{-5}/^\circ\text{C}$.
