

Please check whether you have got the right question paper.

- N.B:
1. Question.No.1 is compulsory.
 2. Attempt any **three** questions out of the remaining **five** questions.
 3. Figures to the **right** indicate **full marks**.
 4. Assume suitable data wherever required but justify the same.

1. Solve any 4 of the following 20
 - (a) Write short note on foam resistant fluids
 - (b) Explain working of cylinder cushion with diagram.
 - (c) Explain construction and working of 4/2 way spool valve with diagram
 - (d) Explain construction and working of AND valve and OR valve.
 - (e) A single acting cylinder is to extend when a push button PB is pressed and retract when PB is released. Using a 3/2 way single solenoid valve develop the pneumatic circuit and also the electrical circuit for the given control task.

2. (a) For the fluid power automobile lift system shown in Figure 1, the air pressure equals 550 KPa 8
 gauge. If the hydraulic piston has 300mm diameter, what is the maximum weight of the automobile that can be lifted? The specific gravity of oil is 0.9. What is the percent error in the answer by ignoring the 1m head of oil between air oil interface surface and bottom surface of piston?

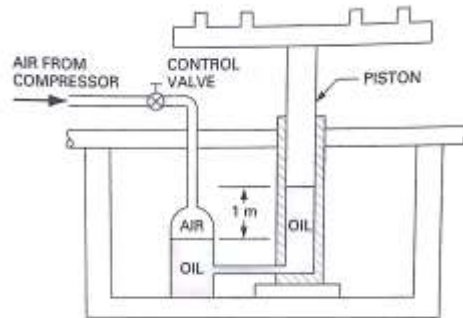

FIGURE 1

- (b) How are pumps classified? Explain the formula for volumetric efficiency , mechanical efficiency and overall efficiency of a pump. 12

3. (a) Explain classification of accumulators. Draw the circuit for accumulator as an emergency power source and explain its operation. 10
- (b) Explain classification of direction control valves based on construction. Explain the symbolic representation of any 3 direction control valves. 10

Q.P. Code : 25804

4. (a) Explain the hydraulic regenerative circuit. What are its advantages and limitations? 9
(b) What is signal conflict? Explain any two methods of signal conflict elimination in pneumatic circuits. 11
5. (a) Explain the construction and working of pneumatic time delay valve. 5
(b) Double acting cylinder is used to perform to and fro operation. Cylinder has to move forward when PB1 button is pressed and continue to and fro motion till 15 cycles of operations is performed. Draw the pneumatic circuit, PLC wiring diagram and ladder diagram to implement this task. 15
6. (a) In a roller bearing greasing machine shown in the Figure 2, the roller bearings are to be clamped by a pneumatic cylinder A. Cylinder B is required to operate a grease press twice for injecting grease into the roller bearing. A pneumatic circuit has to be developed using the cascade method for implementing the control task. 10

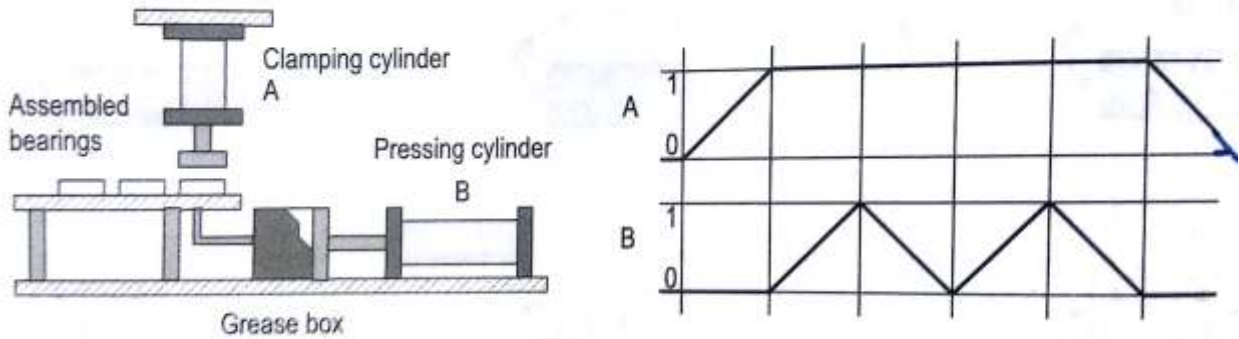

FIGURE 2

- (b) When is hydro-pneumatics used? Explain with an example. 10