

N.B. : 1. Question No **1** is **compulsory**

2. Attempt any **Three** questions from the remaining five questions.

3. Assume any **suitable data** if necessary with justification.

4. Figures to the right indicates full marks

Q.1 Attempt any **Four** questions.

[20]

a) A steel bar of length 1 m is subjected to a 120 kN tensile axial force. The cross- section of the bar is 20 mm x 20 mm. the increase in the length is found to be 0.5 mm and decrease in thickness is 0.003 mm. **Find Young's Modulus, Poisson's Ratio and Bulk Modulus.**

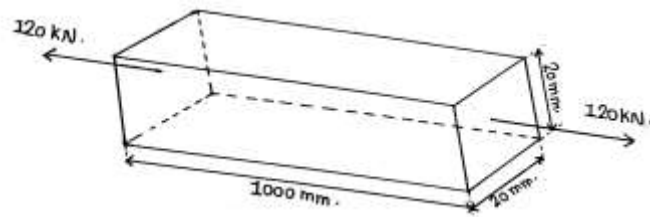

b) **Derive the expression** for Strain Energy stored in a bar due to gradually applied load.

c) **Derive the expression** for the flexural formula.

$$\frac{M}{I} = \frac{\sigma}{y} = \frac{E}{R}$$

d) **Calculate M.I. and Radius of Gyration** of the given section about base axis.

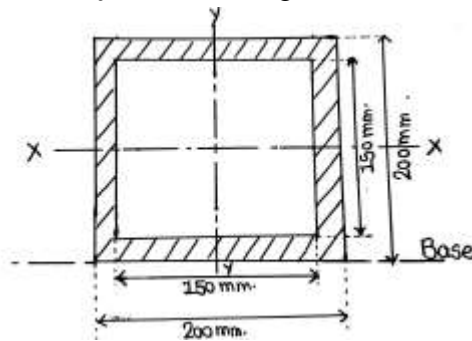

e) **Draw the shear force and bending moment diagram** for a simply supported beam of length L, subjected to UDL over the length.

Q.2 a) Figure shows a stepped shaft ABC with solid circular cross-section is held between a rigid support and a spring support. The diameter and length of the left component is denoted by D1 and L1 respectively and that of right hand component are D2 and L2 respectively. Let E denotes the modulus of elasticity of the shaft. When the temperature increases by 30°C, **Determine change in length of each bar and total compression in spring. Also determine temperature stress**

Q.P. Code: 25760

generated. Take $D_1 = 75 \text{ mm}$, $D_2 = 50 \text{ mm}$, $L_1 = 300 \text{ mm}$, $L_2 = 225 \text{ mm}$, $E = 6 \text{ GPa}$, $\alpha = 100 \times 10^{-6} / ^\circ\text{C}$, $K = 50 \text{ MN/m}$ [10]

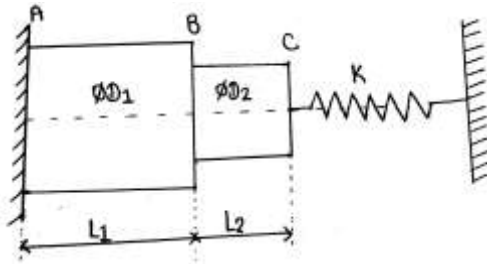

Q.2 b) **Draw the Shear Force and Bending Moment Diagram** for the beam having fixed support and roller support at end A and E respectively and internal hinge at point C. [10]

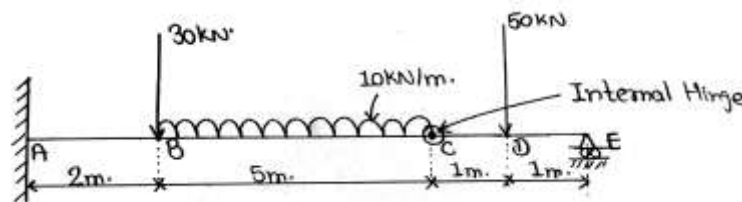

Q.3 a) An I section beam with top flange $100 \text{ mm} \times 30 \text{ mm}$, bottom flange $120 \text{ mm} \times 30 \text{ mm}$, web $120 \text{ mm} \times 30 \text{ mm}$, is simply supported having span of 8 m carries a uniformly distributed load over the span. If the maximum permissible bending stress in tension is 30 MN/m^2 and in compression is 45 MN/m^2 . **Find the UDL intensity and bending stress. Assume sagging bending moment.** [10]

Q.3 b) A concrete block having square cross section as shown in figure. The block weighs 90 kN and a vertical downward load of 20 kN at a point P on the X-X axis, but eccentric about Y-Y axis. **Calculate the distance of the point load At P from the axis Y-Y** if the stress under the block along edge AD is twice the stress under the block along edge BC. [10]

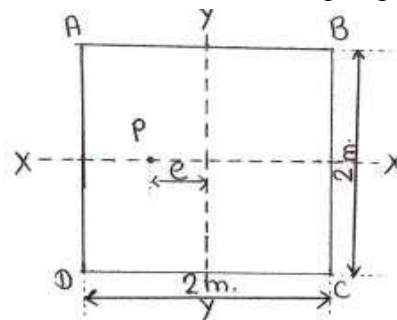

Q.4 a) A hollow shaft with diameter ratio $3/5$ is required to transmit 450 kW at 120 rpm with a uniform twisting moment. The shearing stress in the shaft must not exceed 60 N/mm^2 and the twist in a length of 2.5 m must not exceed 1° . Calculate the minimum external diameter of the shaft satisfying these conditions. Take the modulus of rigidity $G = 8 \times 10^4 \text{ N/mm}^2$. [10]

b) A strained material is subjected to stress system as shown in figure. **Determine the principal planes and principal stresses. Also determine the maximum shear stress and plane on which it acts. Also find normal and shear stress on plane AB inclined at 30° to plane carrying 90MPa .** [10]

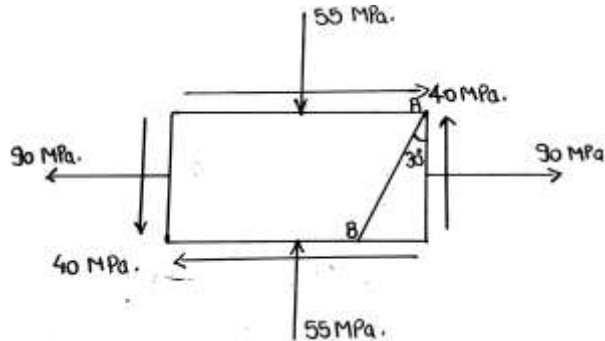

Q.5 a) For the beam shown in figure below, **find slope at point A and deflection at point C and D.** Take $E = 2 \times 10^5 \text{N/mm}^2$ and $I = 1 \times 10^8 \text{mm}^4$. [10]

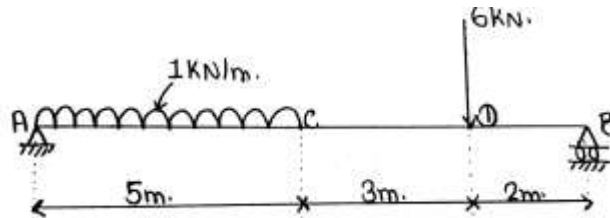

Q.5 b) A beam of T section has a flange $100 \text{mm} \times 15 \text{mm}$ & a web $150 \text{mm} \times 15 \text{mm}$. Draw shear force distribution diagram for a section where shearing force is 60KN . **Find the ratio between maximum shear stress and mean shear stress.** [10]

Q.6 a) Compare the strain energy stored in the two bars of the same material shown in figure a) and b) below, if gradually applied load is same in both bars. **Find the ratio of strain energy in bar a) and b).** [10]

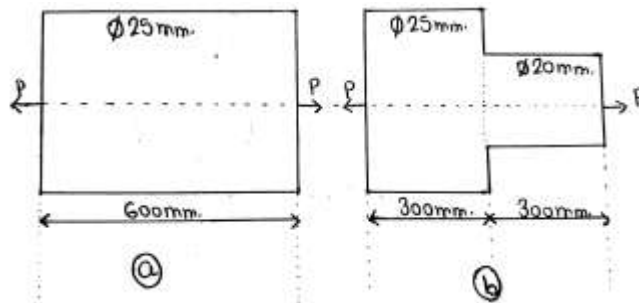

b) **Compare the crippling loads given by Euler's and Rankine's formulae** for tubular steel strut 2.5m having outer and inner diameters 40mm and 30mm respectively, loaded through pin joints at each end. Take yield stress at 320N/mm^2 and Rankine's constant $\alpha = 1/7500$ and $E = 2 \times 10^5 \text{N/mm}^2$. [10]